

Cable Termination Unit Type DT 01



DT 01



- Removes distortion caused by reflections
- H1-housing
- For mounting on DIN-rail (EN 50022)
- No power supply needed

Product Description

Dupline® termination unit for removing distortion caused by reflections from the cable ends.

Ordering Key

DT 01

Type: Dupline®
Type no. _____

Type Selection

Ordering no.
Cable termination unit

DT 01

No code module required

Supply Specifications

Rated operational current
Power dissipation

Typ. 220 µA
≤ 10 mW

General Specifications

Environment	
Degree of protection	IP 20
Pollution degree	3 (IEC 60664)
Operating temperature	-20° to +50°C (-4° to +122°F)
Storage temperature	-50° to +85°C (-58° to +185°F)
Humidity (non-condensing)	0 to 80%
Mechanical resistance	
Shock	15 G (11 ms)
Vibration	2 G (6 to 55 Hz)
Dimensions	
Material (see "Technical Information")	H1-Housing
Weight	45 g

Mode of Operation

When a generator connected to a non-terminated cable emits a square-wave signal, the cable ends will always cause reflections. Depending on distance and frequency, the signal can be distorted to a degree where the information becomes unreliable. However, these reflections can easily be removed by mounting the correct termina-

tion at the cable end. In the case of Dupline® the critical distance between the generator and the far cable end is 2 km and above. Consequently, if as a rule of thumb a DT 01 termination unit is mounted at the cable end when the distance to the channel generator exceeds 1.2 km, reflections are avoided.

Note 1: In case of branches on the cable it is only necessary to mount a second DT 01 if the distance to the nearest DT 01 exceeds 1.2 km. In all other cases a second DT 01 should not be mounted since it increases the capacity of the cable and thereby reduces the transmission distance.

Note 2: The DT 01 is the only unit which can remove reflections and consequently cannot be replaced by other Dupline® modules.

Wiring Diagrams

Example 1

In this example the cable has two branches, and the distance from the channel generator to the cable ends exceeds 1.2 km. Consequently, a DT 01 must be mounted at both ends since no DT 01 is mounted within a distance of 1.2 km from the channel generator.

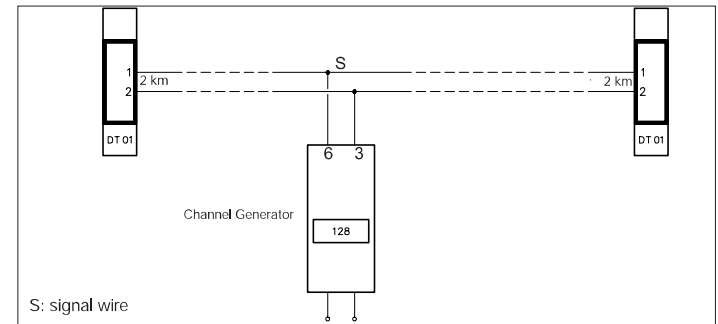

Example 2

In this example the cable also has two branches, and the distance from the channel generator to the far end of the cable exceeds 1.2 km. However, in this case it is not necessary to mount a DT 01 at point B, because the distance to the nearest DT 01 at point A is shorter than 1.2 km.

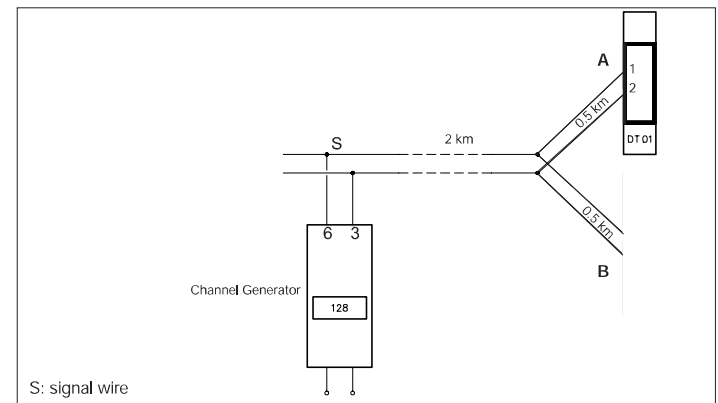

Dimensions (mm)

